

Evaluation of eSwab® for surveillance of MRSA by Xpert MRSA® and culture on pooled samples

K. MARTENS ¹, H. DE BEENHOUWER ^{2*}, J. FRANS ^{3*}, A. VAN DEN ABEEL ^{4*}, R. CARTUYVELS ^{5*}, G. COPPENS ^{1*}

* on behalf of the Bilulu Study Group

¹ Ziekenhuis Oost-Limburg, Genk, Belgium, ² Onze-Lieve-Vrouw Ziekenhuis, Aalst, ³ Imelda Ziekenhuis, Bonheiden, ⁴ AZ Sint-Lucas, Gent, ⁵ Virga Jesseziekenhuis, Hasselt.

Corresponding author: Imeldalaan 9, B 2820 Bonheiden, BELGIUM Phone: +32-15 50 54 60 Fax: +32-15 50 54 79 Email: johan.frans@imelda.be



ABSTRACT

Objectives

The Xpert MRSA® assay (Cepheid), which runs exclusively on the GeneXpert® system (Cepheid), is a FDA approved molecular test to screen for MRSA. It has previously been validated on nose, throat and perineum samples, taken by a double Copan swab® (Copan). This study evaluates, in a multi-centre setting, the use of pooled eSwab® liquid transport medium (Copan) from nose, throat and perineum (NTP) as input sample for the Xpert MRSA® assay in comparison to standard culture technique from the same medium.

Methods

High-risk patients (n=159) were sampled from July until September 2008 in 5 Belgian hospitals. Separate nasal, throat and perineum swabs were collected using the eSwab®.

Four hundred microl of each eSwab® liquid medium from a NTP set was pooled to a final volume of 1200 microl. For the molecular test using the Xpert MRSA® assay, 150 microl of pooled sample was added to the lysis buffer provided in the kit. Further testing was performed according to the manufacturer's instructions. Another 500 microl of pooled sample was transferred to 4 mL of TSB and incubated for 18-24h at 35°C. Ten microl of this enriched culture was transferred to a MRSA-ID® plate (bioMérieux) and screened for the presence of MRSA after 24 and 48 hours.

Results

Twenty-nine (18,2%) samples were MRSA positive on culture. Of these, 28 (96,6%) were Xpert MRSA positive, while 1 (3,4%) tested negative. Of the 130 culture negative samples, Xpert MRSA was negative in 125 (96,2%) but positive in 5 (3,8%) samples. Sensitivity and specificity of the Xpert MRSA assay was 96,6% and 96,2%, respectively. The positive predictive value (PPV) was 84,8% and the negative predictive value (NPV) was 99,2%. No invalid results were observed for the Xpert MRSA® assay.

Conclusion

The results of Xpert MRSA® on eSwab® liquid transport medium pooled from NTP are comparable to the results previously obtained with the double Copan swab®, but fewer invalid results were obtained with eSwab®. The high NPV (99,2%) makes it suitable to rule out MRSA. However, due to the lower PPV (84,8%), positive Xpert MRSA® results need confirmation by culture. For culture, the same eSwab fluid can be used, reducing the risk of sampling bias.

Pooled eSwab® liquid medium from NTP is an adequate matrix for rapid MRSA screening by the Xpert MRSA® assay with culture confirmation possibility without extra sampling.

INTRODUCTION

In Belgium, MRSA is responsible for approximately 25% of nosocomial infections. Controlling MRSA is a primary focus of most hospital infection control programs. Currently, the standard surveillance method for detecting MRSA is culture, which is laborious and time intensive. A rapid and more sensitive method for surveillance of MRSA could represent a definite advantage for infection control programs. We evaluated the use of pooled eSwab® liquid transport medium (Copan) from nose, throat and perineum (NTP) as input sample for the Xpert MRSA® assay in comparison to standard culture technique from the same medium.

SPECIMEN COLLECTION

Samples were collected from July 2008 until September 2008 in 5 different hospitals in Belgium:

- Imelda Ziekenhuis, Bonheiden (IMB)
- Onze-Lieve Vrouw Ziekenhuis, Aalst (OLV)
- Sint-Lucas Ziekenhuis, Gent (SLG)
- Ziekenhuis Oost-Limburg, Genk (ZOL)
- Virga Jesseziekenhuis, Hasselt (VJZ)

Separate nasal, throat and perineum swabs were collected using the eSwab® in a total number of 159 high-risk patients. Four hundred microl of each eSwab® liquid medium from a nasal, throat and perineum set was pooled to a final volume of 1200 microliter. This pooled medium was used for further analysis.

METHODS

Culture and MRSA identification

All samples were cultured in-house using MRSA-ID® media after enrichment in Tryptic Soy Broth. Confirmation and identification of positive samples was performed according to the Belgian national guidelines (2003).

In brief, 500µl of pooled eSwab® liquid medium was inoculated into a staphylococcal enrichment broth (Tryptic Soy broth). After 18-24h incubation at 35°C in ambient air, the enrichment broth was subcultured on a MRSA-ID® plate, which was inspected after 24h and 48h for the presence of MRSA.

Molecular testing using the GeneXpert

Molecular testing was performed on the GeneXpert® system (Cepheid) using the Xpert MRSA® assay (Cepheid). This system combines sample preparation with real time PCR. Results are obtained within 75 minutes with minimal hands-on time. Hundred and fifty microl of pooled sample was added to the lysis buffer provided in the kit. Further processing was according to the manufacturer's instructions.

Each test included a Sample Processing Control (spores of *Bacillus globigii*) that verifies bacterial lysis and specimen processing. This control also detects specimen-associated inhibition of the real-time PCR assay.

Every participating hospital performed the analysis on their own GeneXpert® system. To ensure reproducibility between different sites, inter-lab controls were organised.

Schematic workflow

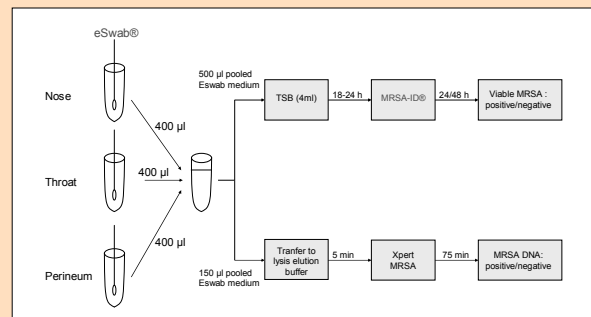

RESULTS

Results of all 159 samples were analysed together to determine clinical sensitivity and specificity. No invalid results were observed for the Xpert MRSA® assay (Cepheid).

Table 1: results of the GeneXpert versus the reference culture method.

	eSwab® culture +	eSwab® culture -	Total
GeneXpert +	28	5	33
GeneXpert -	1	125	126
Total	29	130	159

- Sensitivity = 96,6%
- Specificity = 96,2%
- Positive Predictive Value (PPV) = 84,8%
- Negative Predictive Value (NPV) = 99,2%

DISCUSSION

The Xpert MRSA assay is a CE/IVD and FDA approved assay for the detection of MRSA DNA. It has been validated for use on nasal swabs (cephheid collection device). The assay showed a sensitivity of 86,3%, a specificity of 94,9%, a NPV of 96,6% and a PPV of 80,5%.¹ These numbers have previously been confirmed in a routine setting^{2,3}.

Table 2: Overview of the studies performed

Study	sensitivity	specificity	NPV	PPV	swab (3)
Xpert MRSA manual (1)	86,30%	94,9	96,6	80,5	CCD
De Beenhouwer <i>et al.</i> (2)	94,2	92,4	98	80,3	CCD
Rossney <i>et al.</i> (3)	90	97	98	86	CCD
Martens <i>et al.</i>	96,6	96,2	99,2	84,8	eSwab
(1) only nasal swabs					
(2) nose, throat and perineum swabs					
(3) CCD: 'cephheid collection device'					

We have now evaluated the use of pooled eSwab® medium as input sample for the Xpert MRSA® assay. Results were similar to previous studies with the 'cephheid collection device' (table 2), i.e. high specificity, sensitivity and NPV (96,2%, 96,6% and 99,2%) and a lower PPV (84,8%). This has practical implications for routine use of the Xpert MRSA assay as a screening tool for MRSA. The high NPV makes it suitable to rule out MRSA. On the other hand, a positive GeneXpert result always needs to be confirmed by culture.

Culture can be performed on the same pooled eSwab® medium as was used for the Xpert MRSA assay, reducing the risk of sampling bias.

During a previous study², swabs ('cephheid collection devices') from the different sampling sites (nose, throat and perineum) were pooled in the elution buffer. After analysis with the Xpert MRSA® assay, a high invalid rate (>10%) was observed. Possible explanations are that more PCR inhibitors are added when pooling 3 swabs or that to much elution buffer is absorbed by the swabs. A striking difference was observed in this study using the pooled eSwab® medium, as no invalid results were obtained.

CONCLUSION

- Liquid eSwab® transport medium is a suitable alternative as input sample for the the Xpert MRSA® assay.
- Moreover, the invalid rate reduced significantly.
- The high NPV indicates that the Xpert MRSA® test is an efficient test to exclude the presence of MRSA.
- Positive GeneXpert samples need to be confirmed by culture due to the low PPV (84,8%).

REFERENCES

- 1) Xpert MRSA user manual, Cepheid
- 2) De Beenhouwer *et al.*, Direct detection of MRSA in surveillance samples by Xpert MRSA, ECCMID 2008, poster 1961.
- 3) Rossney *et al.*, Evaluation of the Xpert Methicillin-Resistant *Staphylococcus aureus* (MRSA) Assay Using the GeneXpert Real-Time PCR platform for Rapid detection of MRSA from Screening Specimens, *J Clin Micr*, 46 (10), 3285-3290